

# What agrees, why and how? Symmetrical voice and its variation beyond Austronesian\*

Victoria Chen

Victoria University of Wellington

## 1. Introduction

How are abstract Agree relations realized in narrow syntax? Much recent work has shown that  $\phi$ -feature agreement is not tied specifically to Agree with the  $\phi$ -probe:  $\bar{A}$ -elements, such as topics, foci, *wh*-phrases, and relativized phrases, are capable of triggering  $\phi$ -feature agreement in specific languages, similar to subjects and objects in others (Van Urk 2015; Ostrove 2018; D'Alessandro 2020). Consider below topic-indexing agreement in Mixtec.<sup>1</sup>

(1) *San Martin Peras Mixtec*

- a. **Rà<sub>i</sub>-xá'**antsya rà **Juan<sub>i</sub>** chìkí.  
**he**-cut.PRES he **Juan** tuna  
'Juan is cutting tunas.' (subject topic construction)
- b. **Rì<sub>i</sub>-xá'**antsya rà Juan **chìkí**.  
**it**.AML-cut.PRES he Juan **tuna**  
'Juan is cutting *tunas*.' (Ostrove 2018:vii, viii) (object topic construction)

Languages of this type exhibit a key feature of *discourse configurationality*, defined in É. Kiss 1995 as (2). See also Li and Thompson 1976, Miyagawa 2010, and D'Alessandro 2020 for a similar view.

(2) In a topic-prominent language, the topic is, in a way, an alternative to the subject [in a subject-prominent language]. (É. Kiss 1995:4)

---

\*This project was sponsored by a Marsden Fast Start Grant (#MFP-VUW2012) from Royal Society Te Apārangi. I thank the following speakers for sharing their language: Atrung Kagi, Lisin Kalitang, Dakis Pawan, Ikung Chu, Aki Dai, and Hana Dai. Thanks also to Edith Aldridge, Robert Blust, Ivan Bondoc, Mitcho Erlewine, Shin Fukuda, Brad McDonnell, William O'Grady, Ileana Paul, Masha Polinsky, Eric Potsdam, Lisa Travis, and the audiences at NELS 54, AFLA 27, and AFLA 28 for comments and feedback.

<sup>1</sup>For clarity, I use the term ' $\phi$ -agreement' to refer to the abstract Agree relation between the  $\phi$ -probe and its goal and ' $\phi$ -feature agreement' for the agreement morphology realizing an abstract Agree relation.

This definition reflects a prevalent view in the literature, that natural languages are either subject- or topic-prominent in agreement morphology; in other words,  $\phi$ -feature agreement in a given language is either A- or  $\bar{A}$ -oriented (3). This raises the question in (4).

	Subject-prominent	Topic-prominent
(3) Agree with $[u\phi]$ realized in narrow syntax	✓	✗
Agree with $[u\bar{A}]$ realized in narrow syntax	✗	✓

- (4) Are there languages where the Agree relations with  $[u\phi]$  and  $[u\bar{A}]$  are both indexed in narrow syntax?

In this paper, I show that such a design is not only logically possible but also attested in natural languages—although the type of agreement that manifests this design has received scant attention in the literature. The group of languages that I argue manifests this pattern is western Austronesian languages known as the Philippine-type. Consider below an example from Seediq (ISO639-3 *trv*).

- (5) Maha-ku<sub>k</sub>-na<sub>j</sub>                      bbe-**un** [na    pawan]<sub>j</sub> [ka    yaku]<sub>k</sub>.  
 FUT-1SG.TOP-3SG.SUBJ hit-**PV** [NOM Pawan] [PIVOT 1SG]  
 ‘Pawan will hit *me*.’ (Chang 1997:99) (Patient Voice)

In (5), the affix *-un* on the verb—known in literature as the Patient Voice—occurs where the topic of the sentence is the direct object of the clause. Crucially, both the object topic (‘*me*’) and the grammatical subject (‘Pawan’) are cross-referenced by a person/number-indexing morpheme that indicates their  $\phi$ -features (i.e., *ku* for the first-person singular topic; *na* for the third-person singular subject). Such  $\phi$ -indexing morphemes are traditionally referred to as pronominal clitics in the Austronesian literature, although their precise syntactic status has remained understudied. I will argue that they are essentially agreement affixes—namely,  $\phi$ -feature agreement with the topic and the subject. In this view, Seediq demonstrates a typologically rare type of agreement system where the Agree relations with  $[u\phi]$  and  $[u\bar{A}]$  are spelled out in narrow syntax. Seediq can therefore be characterized as both topic prominent and subject prominent in the sense of (3).

The core focus of the paper concerns the nature of the affixal morphology known as ‘Philippine-type voice’ (*-un* in (5)), the analysis of which has triggered extensive debates in the literature. The goals of the paper are to (i) outline new evidence that this morphology is neither valency-indicating morphemes (e.g., Aldridge 2004 et seq.) nor case agreement (Rackowski and Richards 2005) and (ii) establish a preliminary typology of similar types of agreement found beyond Austronesian, which I unitarily term ‘symmetrical voice’.

This paper is structured as follows. Section 2 reviews basic traits of Philippine-type syntax and outlines new evidence warranting a revised approach to Philippine-type voice. Section 3 presents a revised analysis of this morphology building on previous  $\bar{A}$ -approaches to Philippine-type voice. Section 4 extends this analysis to similar types of verbal morphology in Nilotic and Caucasian, highlighting uniformity and variations among these voice systems. Section 5 summarizes and concludes.

## 2. Austronesian-type voice and alignment: facts and fictions revisited

Many western Austronesian languages display a four-way verbal morphology known as ‘Philippine-type voice’. Descriptively, this morphology indexes the syntactically pivotal phrase of a given clause: to extract the external argument, internal argument, the locative, or the instrument/benefactor, a corresponding voice affix—Actor Voice (AV), Patient Voice (PV), Locative Voice (LV), or Circumstantial Voice (CV)—must be employed, as in (6).

### (6) *Tagalog relativization*

- a. Sino ang [RC b<um>ili/\*-in/\*-an/\*i- ng keyk ]?  
 who PIVOT [RC **buy**<AV>/ \*PV/\*LV/\*CV INDF.CM<sub>2</sub> cake ]  
 ‘Who is the one that bought cakes?’ (Actor Voice)
- b. Ano ang [RC bi-bilih-**in**/\*<um>/\*-an/\*i- ni AJ ]?  
 what PIVOT [RC CONT-**buy-PV**/\*AV/\*LV/\*CV PN.CM<sub>1</sub> AJ ]  
 ‘What is the thing that AJ will buy?’ (Patient Voice)
- c. Na saan ang [RC bi-bilih-**an**/\*<um>/\*-in/\*i- ni AJ ng  
 NA where PIVOT [RC CONT-**buy-LV**/\*AV/\*PV/\*CV PN.CM<sub>1</sub> AJ INDF.CM<sub>2</sub>  
 keyk ]?  
 cake ]  
 ‘Where is the place from which AJ will buy cake?’ (Locative Voice)
- d. Sino ang [RC **i**-bi-bili/\*<um>/\*-in/\*-an ni AJ ng keyk ]?  
 who PIV [RC **CV-buy** /\*AV/\*PV/\*LV PN.CM<sub>1</sub> AJ INDF.CM<sub>2</sub> cake ]  
 ‘Who is the one that AJ will buy cakes for?’ (Circumstantial Voice)

The same set of voice morphology is also obligatory in finite declaratives, as in (7). Analogous to the mapping in (6), where a simple clause is marked in AV, PV, LV, and CV, a special marker labeled as ‘pivot’ must be present on the external argument, internal argument, locative, and instrument/benefactor, respectively, flagging their pivotal status under the corresponding voice. To remain analysis-neutral, I use the labels CM<sub>1</sub> and CM<sub>2</sub> to stand for the morphological marking on nonpivot external arguments (e.g., Tagalog *ni* in (7)) and nonpivot internal arguments (e.g., Tagalog *ng* in (7))<sup>2</sup> throughout the paper.

### (7) *Tagalog declaratives*

- a. B<um>ili si AJ ng keyk mula kay Lia para kay Joy.  
 buy<AV> PN.PIVOT AJ INDF.CM<sub>2</sub> cake P<sub>1</sub> PN.CM<sub>2</sub> Lia P<sub>2</sub> PN.CM<sub>2</sub> Joy  
 ‘AJ bought cake from Lia for Joy.’ (AV)
- b. Bi-bilih-in ni AJ ang keyk mula kay Li para kay Joy.  
 CONT-buy-**PV** PN.CM<sub>1</sub> AJ PIVOT cake P<sub>1</sub> PN.CM<sub>2</sub> Li P<sub>2</sub> PN.CM<sub>2</sub> Joy  
 ‘AJ will buy cake from Li for Joy.’ (PV)

<sup>2</sup>This seemingly thematic role-based mapping applies only to simple transitives. See section 3 for details.

- c. Bi-bilih-an ni AJ ng keyk si Lia para kay Joy.  
 CONT-buy-**LV** PN.CM<sub>1</sub> AJ INDF.CM1 cake PN.PIVOT Lia P<sub>2</sub> PN.CM2 Joy  
 ‘AJ will buy cake from *Li* for Joy.’ (LV)
- d. I-bi-bili ni AJ ng keyk mula kay Li si Joy.  
**CV**-CONT-buy PN.CM1 AJ INDF.CM2 cake P<sub>1</sub> PN.CM2 Li PN.PIVOT Joy  
 ‘AJ will buy cake from *Li* for *Joy*.’ (CV)

## 2.1 Existing approaches to Philippine-type alignment

The fluid case pattern manifested in (7) is known as ‘Philippine-type alignment’, schematized below in (8). Controversies associated with this pattern have revolved around three questions: (i) the nature of the four-way voice alternation, (ii) the exact case value of the three markers ‘pivot’, CM<sub>1</sub>, and CM<sub>2</sub>, and (iii) the trigger of the ‘pivot-only’ constraint (6).

### (8) *Philippine-type alignment*

	a. AV	b. PV	c. LV	d. CV
external argument	<b>Pivot</b>	CM <sub>1</sub>	CM <sub>1</sub>	CM <sub>1</sub>
internal argument	CM <sub>2</sub>	<b>Pivot</b>	CM <sub>2</sub>	CM <sub>2</sub>
locative	P <sub>1</sub>	P <sub>1</sub>	<b>Pivot</b>	P <sub>1</sub>
benefactor	P <sub>2</sub>	P <sub>2</sub>	P <sub>2</sub>	<b>Pivot</b>

One well-adopted family of analyses takes an ergative approach to this pattern, maintaining that pivots are the absolutive occupying a derived A-position within an ergative case system (Payne 1982; Mithun 1994; Aldridge 2004 et seq.; a.o.). In this view, ‘pivot-only’ manifests an Attract Closest constraint (i.e., absolutive-only), whereby Philippine-type voice alternation manifests argument structure alternation, enabling phrases of different types to be promoted to the absolutive. A key assumption of this approach is therefore that each of the four voices differs in transitivity/valency: AV (8a) as an antipassive, PV (8b) as the basic transitive, and the LV (8c) and CV (8d) as two types of high applicatives, featuring valency-changing operations across voice.

Conversely, the accusative approach to these languages maintains that the pivots are topics occupying an  $\bar{A}$ -position driven by obligatory topicalization in finite clauses. Accordingly, voice alternation reflects a change in topic selection, with voice morphology indexing the  $\bar{A}$ -agreement relation with the topic/pivot (Richards 2000; Pearson 2001, 2005; Chen 2017, 2022; see also Chung 1994 for a similar approach to Chamorro voice). Given Relativized Minimality (Rizzi 1990) or the similar notion of  $\bar{A}$ -intervention (Deal 2023), a topic/pivot phrase may enter an Agree relation with [uTOP] without needing to render the highest DP of a clause through a valency-changing operation. This approach therefore assumes no argument structure alternation accompanying voice alternation. In this view, ‘pivot’ is a topic marker independent of case, and CM<sub>1</sub> and CM<sub>2</sub> realize nominative and accusative case, respectively. The key assumptions of the two approaches are summarized in (9). See Chen and McDonnell 2019 for a detailed overview of these two approaches.

(9) *Two families of approaches to Philippine-type alignment*

	<b>a. Ergative approach</b>	<b>b. Accusative approach</b>
<b>Case alignment</b>	ergative-absolutive	nominative-accusative
<b>Locus of voice</b>	within VoiceP	C domain
<b>Nature of voice</b>	voice / applicative head	Agreement morphology
<b>Pivot-marking</b>	absolutive case from T	topic-marking
<b>CM<sub>1</sub></b>	inherent ergative case from tran. Voice	nominative case from T
<b>CM<sub>2</sub></b>	lexical oblique case from V	accusative case from Voice
<b>‘Pivot-only’ restriction</b>	absolutive-only	topic-only

**2.2 New evidence against the ergative approach to Philippine-type alignment**

With more detailed comparative data available, recent research has revealed a series of issues that challenge the ergative view of Philippine-type alignment (9a). The core issues fall under three categories: (i) the case status of the basic markers ‘pivot’, CM<sub>1</sub>, and CM<sub>2</sub>, (ii) the transitivity/valency of AV, LV, and CV clauses (i.e., whether they are indeed antipassives and transitive applicatives, as argued by the ergative approach), and (iii) the nature and locus of Philippine-type voice morphology.

Controversies in (i) lie in the inconsistent distribution of the three markers with their alleged case status in (9a). Specifically, CM<sub>1</sub> has been shown to exhibit the hallmarks of nominative case and incompatible with an inherent ergative case analysis; similarly, CM<sub>2</sub> has been demonstrated to show typical behaviours of structural accusative case, undermining the key assumption in (9a) that the AV is an antipassive with an oblique-marked antipassive object and contrasts with the PV in transitivity. Finally, the consistent binding facts found across five Philippine-type languages (Malagasy, Tagalog, Puyuma, Amis, and Seediq) have revealed that voice alternation in these languages is not accompanied by argument structure alternation (Chen 2017). This challenges the assumption that a pivot must render the highest DP of a clause to access absolutive case. This argues against the ergative approach to both (i) and (ii).

Concerning (iii), recent work has also shown that Philippine-type voice behaves like agreement morphology hosted above argument structure (and not the morphological reflex of Voice/applicative heads hosted within VoiceP). See Pearson 2001, Chen 2017, 2022, and Erlewine et al. 2017 and works cited there for details. Together, these observations lend strong support for the accusative view of Philippine-type languages (9b), suggesting that ‘pivot’ is a marker of informational structure status (topic) that overrides morphological case, yielding an illusory fluid case pattern (10). See Richards 2000 and the works cited above for specific evidence for pivot-marking as a topic marker.

(10) *The accusative approach to Philippine-type alignment*

	a. AV	b. PV	c. LV	d. CV
external argument	NOM <b>Topic</b>	NOM	NOM	NOM
internal argument	ACC	ACC <b>Topic</b>	ACC	ACC
locative	P <sub>1</sub>	P <sub>1</sub>	P <sub>T</sub> <b>Topic</b>	P <sub>1</sub>
instrument/benefactor	P <sub>2</sub>	P <sub>2</sub>	P <sub>2</sub>	P <sub>2</sub> <b>Topic</b>

### 3. Two probes, one goal: Philippine-type voice as the spell-out of parallel chain

A subsequent question following the accusative analysis in (10) is the precise nature of Philippine-type voice affixes. Recent investigations have revealed the mapping in (11) between voice type and pivot selection in several basic constructions found across these languages.

(11) *Mapping between voice choice and pivot selection*

	AV	PV	LV	CV
Unergatives	external argument	*	locative phrase	non-locative adjuncts
Unaccusatives	internal argument	*	locative phrase	non-locative adjuncts
Transitives	external argument	internal argument	locative phrase	non-locative adjuncts
Productive causative	causer	causee	locative phrase	theme
Ditransitives	external argument	recipient	goal	theme
Control constructions	controller	controllee	n/a	theme
SVC	external argument	internal argument	locative phrase	non-locative adjuncts
Generalisation	<b>pivot as subject</b>	<b>pivot as DO</b>	<b>pivot as locative</b>	<b>pivot as anything else</b>

If this morphology constitutes some sort of agreement, what type of abstract Agree relation does it realize? Pre-theoretically, one may draw the generalization in (12) based on the distribution of each voice affix reflected in (11).

(12) *The distributional hierarchy of Philippine-type voice morphology*

- a. AV } PV } CV.
- b. LV is thematic-role oriented (targeting only locative pivots)
- c. Voice morphology does not track the case status of the pivot.

In other words, the choice of voice type manifests a mechanism sensitive to the relative structural height of the pivot with other argument in a given clause (if any)—‘AV’ occurs where the pivot is the highest DP within a CP; ‘PV’ occurs where it is the second highest; ‘CV’ occurs where the pivot is a DP that is neither the first nor the second highest within the clause. Where the pivot is a PP, the form of voice morphology is also sensitive to thematic role: locative pivots trigger LV morphology, whereas other types of adjuncts yield CV morphology. An important take-home message here is therefore that voice selection is neither tied solely to the thematic role nor case status of the pivot, contra the case agreement approach advocated in the literature (Rackowski and Richards 2005). An accusative object as the pivot may trigger either PV or CV morphology, depending on the actual relative structural height of that object. See Chen 2017, 2022 for details.

#### 3.1 Proposal: Philippine-type voice as the spell-out of parallel chain

This complex mapping (11) motivates a revised approach to Philippine-type voice, outlined in (13) with five key assumptions and schematized in (14).

(13) *Proposal: the make-up of a Philippine-type voice system*

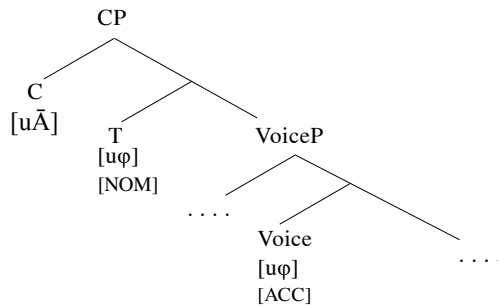

In other words, where a phrase is probed simultaneously by  $[u\bar{A}]$  and a  $\phi$ -probe, the parallel chain relation is assumed to realize as a so-called ‘voice affix’ on the predicate.

(14) *Parallel chain formation (Chomsky 2001, 2005; Kandybowicz 2008; a.o.)*

Two chains  $\alpha$  and  $\beta$  are related by parallel chain formation iff:

- i. Tail ( $\alpha$ ) = Tail ( $\beta$ ), and
- ii. Head ( $\alpha$ )  $\neq$  Head ( $\beta$ ) (Kandybowicz 2008:115)

This analysis draws from the standard assumption under the Minimalist framework that abstract subject and object agreement are present in all natural languages and are unique per clause (Chomsky 2000 et seq.; Miyagawa 2010; Baker 2012). The postulation of the flat  $\bar{A}$ -probe  $[u\bar{A}]$  follows from the recent view of  $\bar{A}$ -feature geometry (Miyagawa 2010; Baier 2018), that  $\bar{A}$ -features are hierarchically arranged, whereby probes may be relativized to different places on this hierarchy, with [TOP] ranked higher than [WH], [FOC], and [REL].

(15)

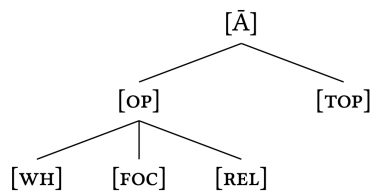

On this approach, a probe may be satisfied by an  $\bar{A}$ -feature ( $[u\bar{A}]$ ) or any lower down on the hierarchy, such as [TOP] and [REL]. Following an early insight from Kuno 1973 that relativization and topicalization in various languages are incompatible in the same clause, I propose that they are driven by the same flat  $\bar{A}$ -probe in Philippine-type languages (16).

(16)

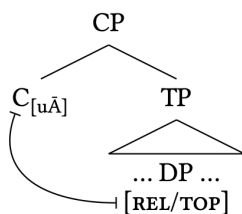

### 3.2 Actor voice

Philippine-type AV morphology appears where the pivot is simultaneously the grammatical subject of a given clause. In other words, it occurs where the topic (or the REL-phrase) of a sentence is the (i) external argument of unergatives/transitives/ditransitives, (ii) causer of productive causatives, (iii) controller of control constructions, or (iv) internal argument of unaccusatives and detransitives. This mapping is exemplified below with examples from Puyuma (17).

(17) *Puyuma*

- a. **M**-u-arak **na** **walak** i arasip.  
 [AV]-dance DEF.PIVOT **child** LOC Arasip  
 ‘Atrung danced in Arasip.’ (AV unergative)
- b. **M**-ekan **na** **bangsaran** dra patraka.  
 [AV]-eat DEF.PIVOT **young.man** INDEF.ACC meat  
 ‘The young man ate some meat.’ (AV transitive)
- c. **M**-u-ekan **na** **patraka**.  
 [AV]-DETR-eat DEF.PIVOT **meat**  
 ‘The meat was eaten up.’ (AV detransitive)
- d. **M**(in)atray na **bangsaran**.  
 [AV]⟨PRF⟩ DEF.PIVOT **young.man**  
 ‘That young man died.’ (AV unaccusative)

I argue that this morphology is the arbitrary spell-out of the parallel chain formed by Agree with  $[u\bar{A}]$  and that with  $[\phi]$  on T, schematized below (18). This approach offers a simple account to the distribution of this morphology as (i) sensitive to locality and (ii) available only to the highest agent per CP, while (iii) not insensitive to the thematic role of the pivot. See Rackowski 2002 and Chen 2017 for details about AV morphology’s distribution.

(18) *AV as the spell-out of the chain formed by Agree with  $[u\bar{A}]$  and  $[u\phi]$  on T*

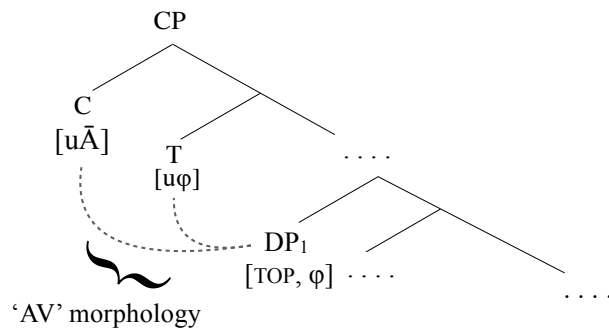



### 3.3 Patient voice

PV morphology in Philippine-type languages also displays a distribution sensitive to the relative structural height of the pivot, evidenced by binding facts (Pearson 2001; Rackowski 2002; Chen 2017): the pivot must be the second highest DP in a given clause.<sup>3</sup>

Possible triggers of ‘PV’ thus include (i) the internal argument of simple transitives (19a), (ii) causee of productive causatives (19b), (iii) controllee in control constructions, and (iv) recipient in double object constructions (19c). Crucially, internal arguments that are not the second-highest DP are incapable of triggering PV morphology. This includes the theme in causative and control constructions—which constitute the third DP of a clause—as well as unaccusative themes (17d), which are the highest/sole argument of the clause.

(19) *Amis*

- a. Tangtang-**en** ni Lisin **k-u** **titi**.  
 COOK-**[PV]** PN.NOM Lisin **PIVOT**-that **pork**  
 ‘Lisin will cook *that pork*.’ (PV transitive)
- b. Pa-pi-takaw-**en** aku **k-una** **wawa** t-una paysu.  
 CAUS-PI-steal-**[PV]** 1SG.NOM **PIVOT**-that **child** ACC-that money  
 ‘I will made *that child* steal that money.’ (PV causative)
- c. Pafeli-**en** aku **k-una** **wawa** t-una paysu.  
 give-**[PV]** 1SG.NOM **PIVOT**-that **child** ACC-that money  
 ‘I gave *the child* that money.’ (PV ditransitive)

Crucially, this locality-sensitive distribution patterns consistently with abstract object agreement. As demonstrated in Baker 2012 and subsequent works, Agree-realizing object agreement across languages is characterized by three traits: (i) unique per clause, (ii) sensitive to locality as available only to the highest DP below the matrix Voice, and (iii) unable to probe into PPs. Consider, for example, object agreement in Amharic ditransitives and causative constructions, where object agreement consistently targets second highest DP—i.e., the recipient in the ditransitive (20a) and the causee in the causative (20b). This mapping displays a distribution analogous to Philippine-type PV morphology (19b–c).

(20) *Amharic (Semitic)*

- a. Ləmma l-almaz məs’əhaf-u-n sət’t’-at.  
 Lemma DAT-Almaz book-DEF-ACC give-(3MS)-**[3FO]**  
 ‘Lemma gave the book to *Almaz*.’ (Baker 2012:258)
- b. Aster was-an as-metaiʃ-ññ.  
 Aster ball-DEF.ACC CAUS-hit-3FEM.S-**[1SG.O]**  
 ‘Aster made *me* kick the ball.’ (Duncan and Aberra 2009)

<sup>3</sup>For specific discussions of the binding facts that give rise to this generalization, see Chen 2017 as well as Pearson 2001, 2005, and Rackowski 2002, for data from Tagalog, Malagasy, Puyuma, Amis, and Seediq.

I argue that PV morphology's consistent patterning with object agreement in distribution is not a coincidence, but a clear sign for the former as manifesting the latter. I propose accordingly that 'PV' is the spell-out of the parallel chain formed by Agree with  $[u\bar{A}]$  and that with  $[u\phi]$  on Voice/v, which yields abstract object agreement. This analysis is illustrated in (21). The fact that some Philippine-type languages employ overt  $\phi$ -feature agreement with the primary object, such as Bunun (ISO 639-3 *bnn*), lends empirical support to the assumed presence of abstract object agreement in these languages.

(21) *PV as the reflex of the chain formed by Agree with  $[u\bar{A}]$  and  $[u\phi]$  on matrix Voice*

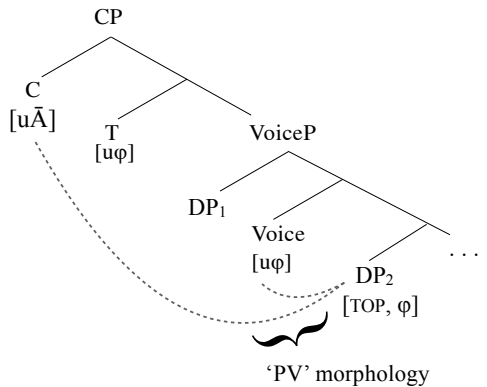

### 3.4 Locative voice

Unlike the first two voices, LV morphology shows a distribution adhering to thematic role: it occurs when the pivot of a given clause is a locative phrase. Triggers of this morphology thus include locative adjuncts or the goal or source in ditransitives, exemplified in (22).

(22) *Paiwan (Ferrel 1969:202; Chang 2006:195, 74)*

- a. Qalup-**an** nua caucau tua vavuy a **gadu**.  
 hunt-**LV** NOM man ACC pig **PIVOT mountain**  
 'The man hunts pigs in *the mountains*' (LV transitive)
- b. P<in>a-pana'-**an** a icu a i **maza** ni palang tay  
 CAU<PRF>-shoot-**LV** **PIVOT this LK LOC here** PN.NOM Palang PN.ACC  
 kui ta zua venan.  
 Kui ACC that deer  
 'Palang made Kui shoot that deer *here*.' (LV causative)
- c. <in>aLap-**an** ti **zepul** ta za paysu ni lavakaw.  
 <PRF>take-**LV** **PN.PIVOT Zepul** ACC that money NOM Lavakaw  
 'Lavakaw took money from *Zepul*.' (LV ditransitive)

This distribution is captured by the analysis in (23), that 'LV' is the spell-out of the parallel chains under Agree with  $[u\bar{A}]$  and that with a  $\phi$ -probe on a locative-selecting P, labelled as  $P_{\text{LOC}}$ . This proposal follows from the well-known fact that various Philippine-type lan-



ingly that this morphology is the spell-out of the abstract Agree relation with  $[u\bar{A}]$ , where the goal is not under Agree relation with any other probes, as in (25).

(25) *CV as a last-resort voice*

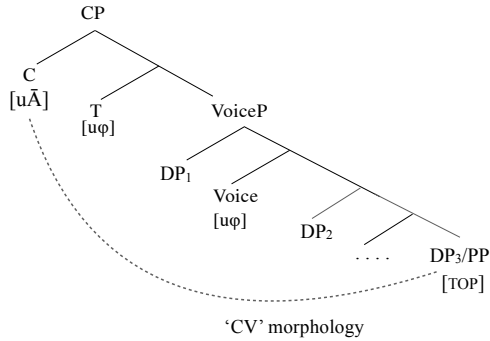

**3.6 Interim conclusion**

The parallel chain approach to Philippine-type voice offers a simpler account for the lack of one-to-one correspondence between voice form and pivot selection on the one hand as well as its mismatch with thematic role or case status on the other. Under this analysis, the seemingly perplexing four-way voice system is essentially an agreement system indexing four types of topicalization: that of (a) subject, (b) direct object, (c) locative phrase, and (d) phrases that are none of the above.

An important consequence of this view is that the ‘pivot-only’ is essentially not an extraction constraint, but the manifestation of the same set of parallel chain relations triggered by Agree with a REL-phrase in relativization—under the assumption that the same set of parallel chains can be driven either by topicalization or relativization. See Van Urk 2015 for a prior treatment for a similar extraction restriction.

**4. Many faces of symmetrical voice: Variations beyond Austronesian**

I have argued that Philippine-type voice is the spell-out of parallel chain relations, as in (26). In what follows, I show that similar types of voice systems, which I unitarily term ‘symmetrical voice’, is attested beyond Austronesian and how comparative data from these languages verify six logically possible loci of variations associated with symmetrical voice.

(26) *Proposal: Symmetrical voice as the spell-out of parallel chain*

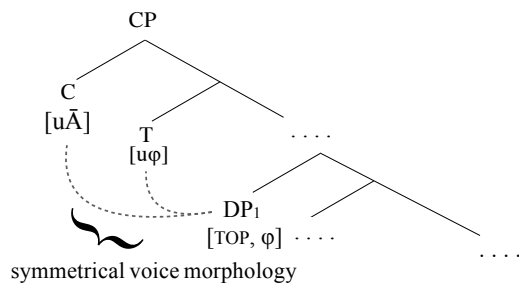

*Symmetrical voice within and beyond Austronesian*

- (27)
- a. **Compatibility with different case alignments:** symmetrical voice should be independent of case alignment and compatible with either accusative or ergative case systems
  - b. **The exact chain relations spelled out:** The exact chain relations spelled out in narrow syntax may vary across languages
  - c. **The type of  $\bar{A}$ -operation(s) that trigger voice morphology:** may also vary across languages
  - d. **The locus of the probes triggering the parallel chain**
  - e. **Presence or absence of  $\phi$ -feature agreement:** Whether or not the goal of the parallel chain also triggers  $\phi$ -feature agreement
  - f. **Presence or absence of Move following Agree**

#### 4.1 Variations 1-3: number of voice, case alignment, and extraction constraints

Some western Nilotic languages, including Agar, Kurmuk, and Dinka, exhibit a three-way voice system that share several hallmarks of Austronesian-type voice (Andersen 1991, 2015; Van Urk 2015; Erlewine et al. 2017). Consider the examples from Kurmuk in (28).

- (28) *Kurmuk (Andersen 2015:510)*
- a.  $\text{t}^{\text{a}}\text{a}\text{r}\text{a}\text{k} \text{ } ^{\text{b}}\text{b}\text{o}\text{o}\text{r}\text{-}\text{u} \quad \text{d}\text{e}\text{l} \text{ k}\lambda \quad \eta\text{i}\text{r}.$   
 person skin-PST.SUBJ.T goat PREP knife  
 ‘The man skinned a goat with a knife.’ (subject topic)
  - b.  $\text{d}\text{e}\text{e}\text{l} \text{ b}\text{o}\text{o}\text{r}\text{-}\text{u}\text{t}\text{-}\text{i} \quad \eta\lambda \quad \text{t}^{\text{a}}\text{a}\text{r}\text{a}\text{k} \text{ k}\lambda \quad \eta\text{i}\text{r}.$   
 goat skin-PST-OBJ.T NOM person PREP knife  
 ‘The man skinned *the* goat with a knife.’ (object topic)
  - c.  $\eta\text{i}\text{r} \text{ b}\text{o}\text{o}\text{r}\text{-}\text{u}\text{t}\text{-}\text{i} \quad \text{d}\text{e}\text{l} \quad \eta\lambda \quad \text{t}^{\text{a}}\text{a}\text{r}\text{a}\text{k}$   
 knife skin-PST-OBL.T goat NOM person  
 ‘The man skinned a goat with *the* knife.’ (oblique topic)

All three languages feature three-way verbal morphology alternating for the grammatical role of the topic, the core properties of which are summarized in (29) (Andersen 1991, 2015; Van Urk 2015). Note the similarities between these traits and those of Austronesian voice outlined in the preceding sections.

- (29)
- a. Three-way verbal morphology indexing the grammatical role of the topic: subject, direct object, and others
  - b. Nominative-accusative case alignment
  - c. A ‘last resort’-type third voice known as oblique topic construction
  - d. Voice morphology present on the highest verbal head with default marking on all lower heads (as in Austronesian)
  - e. Same set of voice morphology present in several types of  $\bar{A}$ -operations.

A similar type of verbal inflection is found in the Caucasian language Abaza (ISO 639-3 *abq*), known previously in the literature as *wh*-agreement (e.g., O’Herin 1993, 2002). In Abaza, this morphology inflects for the grammatical role of various  $\bar{A}$ -elements including topics, relativized phrases, and *wh*-phrases (O’Herin 1993, 2002). Crucially, in this ergative language, the affixal alternations on the verb distinguish between the absolutive DPs, non-absolutive arguments (the ergatives and various types of indirect objects), and at least three other verbal affixes targeting different types of adjuncts: temporal, locative, and manner.

This agreement system is illustrated below with examples of relativization reported in Arkadiev 2020 and Arkadiev and Caponigro 2021. The ‘voice affix’ *j-*, roughly equivalent to Austronesian Actor Voice or the subject voice in western Nilotic, appears where the head noun is an absolutive DP. This includes the sole phrase of intransitives (30a) and ditransitive themes (30b).<sup>4</sup> Where the relativized phrase is the ergative agent, an indirect object (IO), or an applied object (AO), the verb carries a distinct ‘voice affix,’ *z-* (or allomorph *zə-*) (30a–c).

(30) *Abaza* (Arkadiev and Caponigro 2021:78-79)

- a. [awaʔa **j**-ʕa-ta-χa-k<sup>w</sup>a-z]  
 there **REL.SUBJ**-CSL-LOC-remain-PL-PST.NFIN  
 ‘those who remained there’ **(Subject RC (S))**
- b. [a-ph<sup>w</sup>əspa **j**-lə-s-tə-z] a-ĉa  
 DEF-girl **REL.SUBJ**-3SG.F.IO-1SG.ERG-give-PST.NFIN DEF-apple  
 ‘the apple I gave to the girl’ **(Subject RC (O))**
- c. [a-ph<sup>w</sup>əspa ĉa lə-**z**-tə-z] a-ĉ<sup>ʔ</sup>k<sup>w</sup>ən  
 DEF-girl apple 3SG.F.IO-**REL.NSUBJ**-give-PST.NFIN DEF-boy  
 ‘the boy who gave an apple to the girl’ **(Nonsubj RC (A))**
- d. [ĉa **z**-s-tə-z] a-aph<sup>w</sup>əspa  
 apple **REL.NSUBJ**-1SG.ERG-give-PST.NFIN DEF-girl  
 ‘the girl whom I gave an apple’ **(Nonsubj RC (IO))**
- e. d-h<sup>w</sup>a  
 3SG.H.ABS-say(IMP)  
 [jəz-**zə**-b-χ<sup>w</sup>ʕa-z]  
 3SG.N.ABS-**REL.NSUBJ**-BEN-2SG.F.ERG-buy-PST.NFIN  
 ‘Say whom you bought it for!’ **(Nonsubj RC (AO))**

Adjunct relativization also employs several different verbal affixes conditioned by the thematic role of the adjunct – *ʔa-* (locative), *an-* (temporal), or *š* (*manner*). Consider (31).

(31) *Abaza* (Arkadiev and Caponigro 2021:80)

<sup>4</sup>In Arkadiev and Caponigro 2021, the prefix *j-* is glossed as REL.ABS. I have glossed it as REL.SUBJ here to reflect the fact that this agreement system is not case-conditioned, as shown by the fact that ergative DPs and different types of indirect objects share the same voice affix.



To conclude, symmetrical voice is attested beyond Austronesian. Importantly, across these languages, this morphology does not always display a one-to-one correspondence with the case status of the pivot/agreement trigger, and hence cannot be analyzed as case agreement. Notably, the types of  $\bar{A}$ -operation that trigger ‘voice morphology’ are generally consistent across Dinka, Abaza, and Philippine-type Austronesian languages (34). In Dinka and Austronesian, the triggers include topicalization and relativization. *Wh*-movement in Dinka also employs obligatory voice agreement. The same applies to *wh*-clefts in Abaza and Philippine-type Austronesian, which is standardly analyzed as an instance of relativization (Potsdam 2006 et seq.; Arkadiev and Caponigro 2021).

(34)	Philippine-type languages	topicalization, relativization (including <i>wh</i> -clefts)
	Dinka (Nilotic)	topicalization, relativization, <i>wh</i> -questions
	Abaza (Caucasian)	relativization (including <i>wh</i> -clefts)

#### 4.2 Variation 4: the locus of $[u\bar{A}]$ and $[u\phi]$

The fourth locus of variation concerns the exact locus of the  $\bar{A}$ -probe and the  $\phi$ -probe that triggers the parallel chain. Recent work has demonstrated the lack of the  $A/\bar{A}$  distinction in Dinka and argued accordingly that the language exhibits a flat  $\bar{A}$ -probe located on the same head with the  $\phi$ -probe, as in (35a). Contra Dinka, Philippine-type languages exhibit a clear  $A/\bar{A}$ -distinction evidenced by binding facts, whereby promotion-to-pivot shows prototypical  $\bar{A}$ -properties and no  $A$ -properties (Pearson 2001; Chen 2017). This suggests that  $[u\bar{A}]$  and the  $\phi$ -probe are located on distinct heads in these languages (35b), yielding a binding parameter distinct from Dinka. See Chen 2017 for a comparison of the binding facts in these languages with Dinka.

(35) *Variation in the locus of the probes that trigger parallel chain*

a. Dinka

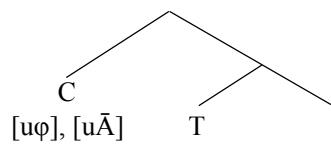

b. Philippine-type Austronesian languages

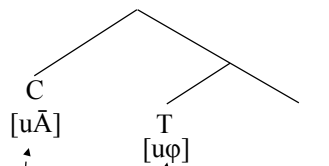

*promotion-to-pivot/subject    promotion-to-pivot    promotion-to-subject*

#### 4.3 Variation 5: presence or absence of $\phi$ -feature agreement following Agree

A fifth locus of variation concerns the presence or absence of  $\phi$ -feature agreement with the pivot, i.e., the trigger of the parallel chain. As noted in section 1, recent work has shown that  $\bar{A}$ -elements are capable of triggering  $\phi$ -feature agreement in some languages. This yields the prediction that the pivot/trigger of this morphology may also yield  $\phi$ -feature agreement. This prediction is borne out. Consider firstly an example from Dinka, where voice affix co-occurs with  $\phi$ -feature agreement (36).



- (36) *Dinka*  
 a. Cuŋin à-**céem** Áyèn nè pǎal.  
 food 3s.eat-OV Ayen.GEN P knife  
 ‘Food, Ayen is eating with a knife.’ (Van Urk 2015:61) (Object Voice)

Similarly, in Abaza, voice morphology co-occurs with  $\phi$ -feature agreement (37).

- (37) *Abaza*  
 a. a-sabəy-k<sup>w</sup>a dəzda yə-r-pfə  
 DEF-child-PL who REL.SUBJ-3PL-look  
 ‘Who is taking care of the children?’ (O’Herin 2002:252)

A similar design is also found in Austronesian. As noted in section 1, many Philippine-type languages employ two series of person/number-indexing morphemes on the verb, which cross-reference the grammatical subject and the topic/pivot, as seen in the Puyuma example (38) and the Seediq example in (5). In these languages, the  $\phi$ -features of both the topic/pivot and the grammatical subject are indexed by a bound morpheme attached to the verb. I argue that these morphemes are exactly  $\phi$ -feature agreement with these arguments.<sup>5</sup>

- (38) *Puyuma*  
 a. **Tu<sub>i</sub>**-trakaw-ay-**yu** dra paysu kan Senten<sub>i</sub>.  
**3.SUBJ-steal-LV-2SG.TOP** INDEF.ACC money PN.NOM Senten  
 ‘Senten stole money from you.’ (Locative Voice)

The variation in the presence or absence of these three sets of  $\phi$ -feature agreement thus reinforces the view that agreement is a possible but not necessary outcome of Agree.

#### 4.4 Variation 6: presence of absence of Move following Agree

Much recent work has also shown that overt  $\bar{A}$ -movement is not a necessary outcome of Agree. Abaza provides specific evidence for this optionality. As (39a–b) shows, a *wh*-phrase can either surface sentence-initially or remain in-situ. Note the consistent presence of the voice morphology *z-* in both patterns, suggesting the presence of Agree in both cases.

<sup>5</sup>Although often described as clitic pronouns in the Austronesian literature, these morphemes behave more like agreement affixes under the criteria discussed in recent work (Preminger 2009; Kramer 2014; Yuan 2021; a.o.). To begin with, analyzing these morphemes as  $\phi$ -feature agreement avoids the unusual assumption that Philippine-type languages use a dedicated series of pronominal clitics for topics. Second, doubled clitics are typically optional, whereas these morphemes are obligatory. Third, their distribution is not semantically restricted, unlike pronominal clitics, which index specific DPs. Fourth, the subject-indexing affixes in some Philippine-type languages inflect for the TAM values of the clause, a key trait of agreement. Fifth, the ‘object clitic’ in these languages behaves like object agreement by being unique per clause and obligatorily cross-referencing the highest internal argument. Sixth, the subject- and topic-indexing affixes in some Philippine-type languages form a single portmanteau affix, a hallmark of agreement. Finally, these clitic systems consistently possess a null third-person pivot form, a common gap in agreement paradigms.

- (39) a. Dizda kitab y-**z**-**ɪ**ma-m?  
 who book 3si-**NSUBJ.WH**-have-NEG  
 ‘Who doesn’t have a book?’ (Wh-fronting)
- b. S-kitab dɪzda y-na-**z**-axu?  
 1s-book who 3si-**PV-NSUBJ.WH**-take  
 ‘Who took my book?’ (O’Herin 1993:45, 37) (Wh-in-situ)

The obligatoriness of voice morphology—alongside the optionality of *wh*-fronting—suggests that Move is indeed not a necessary outcome of Agree and that the flexibility may manifest within a single language. Austronesian languages provide further empirical support for this view. Only a small number of Philippine-type languages require the topic/pivot to surface in a particular linear order. One of these languages is Malagasy, where the pivot is obligatorily sentence-finally, which is standardly assumed to derive from  $\bar{A}$ -movement followed by predicate fronting (e.g., Pearson 2001; Aldridge 2004). Most of the languages feature pivot-in-situ, where the pivot remains in its  $\theta$ -position regardless of voice, or flexible word order among nominals. See Chen 2017 for an overview. Crucially, all three types of languages display the same type of voice system and the ‘pivot-only’ constraint in relativization. This variation mirrors the flexibility in  $\bar{A}$ -movement observed in Abaza (39), supporting the view that overt  $\bar{A}$ -movement is not the necessary outcome of Agree.

## 5. Conclusion

In this paper, I have argued that the verbal morphology known as ‘Philippine-type voice’ or ‘*wh*-agreement’ is a feature of *discourse configurationality* (É. Kiss 1995; Miyagawa 2010); this morphology constitutes the arbitrary spell-out of parallel chain (2001; Kandybowicz) probing the same goal (an  $\bar{A}$ -element), which I refer to as ‘symmetrical voice’. An important implication of this analysis is that  $\phi$ -feature agreement is not the sole available means of realizing abstract  $\bar{A}$ -agree relations—another is the arbitrary spell-out of parallel chains, as widely attested in Austronesian. Future investigation of this type of hybrid agreement will shed more light on the relationship between Agree and agreement.

I have also shown that symmetrical voice is attested beyond Austronesian and found in both Nilotic and Caucasian, with six points of variation identified across the three families: (a) the case alignment of the language, (b) the number of voice distinctions (i.e., the exact parallel chains spelled out), (c) the locus of the probes triggering voice morphology, (d) the presence or absence of  $\phi$ -feature agreement of the goal, (e) the presence or absence of Move following Agree, and (f) the types of  $\bar{A}$ -operations that trigger overt voice morphology. Two main implications of this observation are (i) symmetrical voice is a means for indicating  $\bar{A}$ -Agree relations and (ii) subject prominence and topic prominence are not necessarily a dichotomy: discourse configurational languages may employ agreement for both. To the best of my knowledge, there has been no report of subject-prominent languages that employ symmetrical voice. This reveals an understudied asymmetry between subject-prominent and topic-prominent languages—only the latter exhibits a possible design that enables a specification of the A-agree relation of a syntactically prominent  $\bar{A}$ -element (e.g., topic).

## References

- Aldridge, Edith. 2004. Ergativity and word order in Austronesian languages. Doctoral dissertation, Cornell University, Ithaca, NY.
- Andersen, Torben. 1991. Subject and topic in Dinka. *Studies in Language* 15(2):265–294.
- Andersen, Torben. 2015. Syntacticized topics in Kurmuk: A ternary voice-like system in Nilotic. *Studies in Language* 39:508–54.
- Arkadiev, Peter. 2020. Syntax in morphological guise: Interrogative verbal morphology in Abaza. *Linguistic Typology* 24(2):211–251.
- Arkadiev, Peter, and Ivano Caponigro. 2021. Conveying content questions without wh-words: Evidence from Abaza. In *Proceedings of Sinn und Bedeutung 25*, ed. by Hazel Pearson Yasutada Sudo Patrick Grosz, Luisa Mart ´ı and Sarah Zobel, 73–94.
- Baier, Nicholas. 2018. Anti-Agreement. Doctoral dissertation, UC Berkeley, CA.
- Baker, Mark. 2012. On the relationship of object agreement and accusative case: evidence from Amharic. *Linguistic Inquiry* 43:255–274.
- Chang, Anna. 2006. A reference grammar of Paiwan. Doctoral dissertation, ANU.
- Chang, Yung-Li. 1997. Voice, case, and agreement in Seediq and Kavalan. Doctoral dissertation, National Tsing Hua University.
- Chen, Victoria. 2017. A reexamination of the Philippine-type voice system and its implications for Austronesian primary-level subgrouping. Doctoral dissertation, University of Hawai’i.
- Chen, Victoria. 2022. When Philippine-type voice meets Indo-European-type voice: Insights from Puyuma. *Journal of East Asian Linguistics* 31:517–550.
- Chen, Victoria, and Bradley McDonnell. 2019. Western Austronesian Voice. *Annual Review of Linguistics* 5:173–195.
- Chomsky, Noam. 2000. Minimalist inquiries: The framework. In *Step by step: Essays on minimalist syntax in honor of Howard Lasnik*, ed. by Juan Uriagereka Roger Martin, David Michaels and Samuel Jay Keyser, 89–155. Cambridge, MA: MIT Press.
- Chomsky, Noam. 2001. Derivation by phase. In *Ken Hale: A life in language*, ed. by M. Kenstowicz, 1–52. Cambridge, MA: MIT Press.
- Chomsky, Noam. 2005. Three factors in language design. *Linguistic Inquiry* 36:1–22.
- Chung, Sandra. 1994. Wh-agreement and “referentiality” in Chamorro. *Linguistic Inquiry* 25(1):1–44.
- D’Alessandro, Roberta. 2020. Agreement across the board: Topic agreement in Ripano. In *Ken Hale: A life in language*, ed. by P. Smith et al., 235–270. Berlin: Language Science Press.
- Deal, Amy Rose. 2023. Interaction, satisfaction, and the PCC. *Linguistic Inquiry* 55:39–94.
- Duncan, Tamara Sorenson, and Daniel Abera. 2009. Amharic causatives revisited. Poster presented at Department of Linguistics 40th Reunion, University of Alberta.
- É. Kiss, Katalin. 1995. Introduction. In *Discourse configurational languages*, ed. by Katalin É. Kiss, 3–27. Oxford: Oxford University Press.
- Erlewine, Michael, Theodore Levin, and Coppe van Urk. 2017. Ergativity and Austronesian-type voice systems. In *Oxford handbook of ergativity*, ed. by Jessica Coon, Diane Massam, and Lisa Travis, 373–396. Oxford: Oxford University Press.

- Ferrel, Raleigh, ed. by. 1969. *Taiwan aboriginal groups: problems in cultural and linguistic classification*. Taipei: Academia Sinica.
- Kandybowicz, Jason. 2008. *The grammar of repetition*. Amsterdam: John Benjamins.
- Kramer, Ruth. 2014. Clitic doubling or object agreement: The view from Amharic. *Natural Language and Linguistic Theory* 32:593–634.
- Kuno, Susumu. 1973. *The Structure of the Japanese Language*. Cambridge: MIT Press.
- Li, Charles, and Sandra Thompson. 1976. Subject and topic: a new typology of language. In *Subject and topic*, ed. by Charles N. Li, 457–461. New York: Academic Press.
- Mithun, Marianne. 1994. The implications of ergativity for a Philippine voice system. In *Voice: Form and function*, ed. by B. Fox and P. Hopper, 247—277. Amsterdam: John Benjamins.
- Miyagawa, Shigeru. 2010. *Why Agree? Why Move?*. Cambridge, MA: MIT Press.
- O’Herin, Brian. 1993. Wh-agreement in Abaza. In *Syntax and Semantics at Santa Cruz*, ed. by Eric Potsdam, volume 2, 25–56.
- O’Herin, Brian. 2002. *Case and agreement in Abaza*. Dallas, Texas: SIL International and University of Texas at Arlington.
- Ostrove, Jason. 2018. When phi-agreement targets topics: The view from San Mart´in Peras Mixtec. Doctoral dissertation, UCSC, CA.
- Payne, Thomas. 1982. Role and reference related subject properties and ergativity in Yup’ik Eskimo and Tagalog. *Studies in Language* 6:75–106.
- Pearson, Matthew. 2001. The clause structure of Malagasy: A minimalist approach. Doctoral dissertation, UCLA, CA.
- Pearson, Matthew. 2005. The Malagasy subject/topic as an  $\bar{A}$ -element. *Natural Language and Linguistic Theory* 23:381–457.
- Potsdam, Eric. 2006. More concealed pseudoclefts in Malagasy and the clausal typing hypothesis. *Lingua* 116(12):2154–2182.
- Preminger, Omer. 2009. Breaking Agreements: Distinguishing agreement and clitic doubling by their failures. *Linguistic Inquiry* 40:619–666.
- Rackowski, Andrea. 2002. The structure of Tagalog: Specificity, voice, and the distribution of arguments. Doctoral dissertation, MIT, Cambridge, MA.
- Rackowski, Andrea, and Norvin Richards. 2005. Phase edge and extraction: A Tagalog case study. *Linguistic Inquiry* 36:565–599.
- Richards, Norvin. 2000. Another look at Tagalog subjects. In *Formal issues in Austronesian linguistics*, ed. by I. Paul, V. Phillips, and L. Travis, 105–116. Dordrecht: Kluwer.
- Rizzi, Luigi. 1990. *Relativized minimality*. Cambridge, MA: MIT Press.
- Van Urk, Coppe. 2015. A uniform syntax for phrasal movement: A case study of Dinka Bor. Doctoral dissertation, MIT, Cambridge, MA.
- Wu, Chun-ming. 2013. The syntax of linking constructions in Mayrinax Atayal and Sinvaudjan Paiwan. Doctoral dissertation, National Tsing-hua University.
- Yuan, Michelle. 2021. Diagnosing object agreement vs. clitic doubling: An Inuit case study. *Linguistic Inquiry* 52:153–179.